

On the existence of wavelets for non-expansive dilation matrices

DARRIN SPEEGLE

Department of Mathematics, Saint Louis University, 221 N. Grand Boulevard

St. Louis, MO 63103, USA

E-mail: speegled@slu.edu

Received September 22, 2002

ABSTRACT

Sets which simultaneously tile \mathbb{R}^n by applying powers of an invertible matrix and translations by a lattice are studied. Diagonal matrices A for which there exist sets that tile by powers of A and by integer translations are characterized. A sufficient condition and a necessary condition on the dilations and translations for the existence of such sets are also given. These conditions depend in an essential way on the interplay between the *eigenvectors* of the dilation matrix and the translation lattice rather than the usual dependence on the eigenvalues. For example, it is shown that for any values $|a| > 1 > |b|$, there is a (2×2) matrix A with eigenvalues a and b for which such a set exists, and a matrix A' with eigenvalues a and b for which no such set exists. Finally, these results are related to the existence of wavelets for non-expansive dilations.

1. Introduction and preliminaries

Let \mathcal{D} be a collection of invertible $n \times n$ matrices, and \mathcal{T} a collection of points in \mathbb{R}^n . A $(\mathcal{D}, \mathcal{T})$ wavelet is a function $\psi \in L^2(\mathbb{R}^n)$ such that

$$\{|A|^{1/2}\psi(Ax + k) : A \in \mathcal{D}, k \in \mathcal{T}\}$$

is an orthonormal basis for $L^2(\mathbb{R}^n)$. The following problem was formalized in [15]:

Problem 1. *For which pairs $(\mathcal{D}, \mathcal{T})$ do there exist wavelets?*

Keywords: Tiling, group actions, orthonormal wavelet, MSF wavelet, non-expansive dilations.

MSC2000: 42C15.

Problem 1 is far from solved even in dimension one. In fact, it seems as though a solution to the spectral set conjecture will be required before a full solution to Problem 1 will be known. In this paper, we will assume that \mathcal{T} is a full rank lattice, and that $\mathcal{D} = \{A^j : j \in \mathbb{Z}\}$ for some *invertible* matrix A . This set-up, while much more restrictive than that proposed by Wang, is far more general than most papers on wavelets allow. In particular, with the exception of sporadic examples in [2], [8], [11] and [15], no papers have allowed the dilation matrices not to be expansive (all eigenvalues bigger than one in modulus). This is probably because almost no examples of existence of such wavelets were known prior to this paper. Contrast this with the continuous wavelet case where non-expansive dilations are well-studied in [13], [12].

There have been several partial results concerning Problem 1 to date. In [3], it was shown that if A is expansive and $\mathcal{D} = \{A^j : j \in \mathbb{Z}\}$, then there always exist $(\mathcal{D}, \mathbb{Z}^n)$ wavelets. In fact, it was shown that the wavelets can be chosen to be $(\mathcal{D}, \mathcal{T})$ MSF wavelets; namely, they can be chosen such that $\hat{\psi} = I_E$, the indicator function on a set. In general, an MSF wavelet is a wavelet such that $|\hat{\psi}| = I_E$ is also the Fourier transform of a wavelet. MSF wavelets have been studied in [3], [4], [7], and [14] among others. It was also shown in [1] that whenever $\mathcal{D} = \{A^j : j \in \mathbb{Z}\}$ and $A^j(\mathbb{Z}^n) \cap \mathbb{Z}^n = \{0\}$ for all $j \neq 0$, then the *only* $(\mathcal{D}, \mathbb{Z}^n)$ wavelets that exist are MSF wavelets. Thus, MSF wavelets seem to play a special role in Problem 1.

Problem 2. *For which pairs $(\mathcal{D}, \mathcal{T})$ do there exist MSF wavelets?*

Problems 1 and 2 should be seen as complementary problems to the problem of characterizing wavelets via the Fourier transform as in the recent paper [8], where they consider non-expansive matrices. In fact, there is a strong interplay between the examples of matrices that yield wavelets and the examples of matrices for which characterizing equations are known, with progress in the one question leading to natural questions in the other. In particular, for some of the matrices in [8] for which characterizing equations are known (see Theorem 4.1 in this paper for an exact statement), it is shown in this paper that no wavelets exist. It is also shown in this paper that wavelets exist for matrices for which no characterizing equations are currently known.

A characterization of MSF wavelets was given in [15] and other places, which states that when A is invertible, $\mathcal{D} = \{A^j : j \in \mathbb{Z}\}$, and \mathcal{T} is a full rank lattice, then ψ satisfying $|\hat{\psi}| = I_E$ is a $(\mathcal{D}, \mathcal{T})$ (MSF) wavelet if and only if

$$\begin{aligned} \{A^t(E) : A \in \mathcal{D}\} &\text{ is a tiling of } \mathbb{R}^n, \text{ and} \\ \{E + \gamma : \gamma \in \mathcal{T}'\} &\text{ is a tiling of } \mathbb{R}^n, \end{aligned}$$

where A^t is the transpose of A and \mathcal{T}' is the dual lattice of \mathcal{T} . Here, we use *tiling* loosely so that it means simply an almost everywhere partition of \mathbb{R}^n .

This brings us to the closely related

Problem 3. *For which pairs $(\mathcal{D}, \mathcal{T})$ do there exist sets E such that $\{A(E) : A \in \mathcal{D}\}$ and $\{E + \gamma : \gamma \in \mathcal{T}\}$ are tilings of \mathbb{R}^n ?*

Schulz and Taylor [13] have several characterizations on A for when there exist E such that $\{A^j(E) : j \in \mathbb{Z}\}$ is a tiling. In particular, they showed that there is such a set E that has finite measure if and only if $|\det(A)| \neq 1$. We study when the set E can also be chosen to tile \mathbb{R}^n by translations. The main feature of this paper is to show that it is **not** the eigenvalues of A that determine in general whether there exists a wavelet, but rather the precise nature of the interplay between the eigenvectors and the integer lattice. This is made most explicit in

Theorem 4.3

Let $|a| > 1 > |b|$. There is a matrix A with eigenvalues a and b such that there exists an (A, \mathbb{Z}^2) wavelet and a matrix M with eigenvalues a and b for which there does not exist an (M, \mathbb{Z}^2) wavelet.

Theorem 4.3 gives the first example of wavelets for dilations A with eigenvalues on both sides of one in modulus. (In [15], some of the matrices in \mathcal{D} could be chosen to be non-expansive.)

Finally, we set notation. A will denote an invertible $n \times n$ matrix with transpose $B = A^t$. $\Gamma \subset \mathbb{R}^n$ will denote a full rank lattice with dual lattice Γ' . We say a function f tiles \mathbb{R}^n by (Γ) translations if $\sum_{\gamma \in \Gamma} f(x + \gamma) = 1$ a.e., and a function tiles \mathbb{R}^n by \mathcal{D} dilations if $\sum_{A \in \mathcal{D}} f(Ax) = 1$ a.e. When $\mathcal{D} = \{A^j : j \in \mathbb{Z}\}$, we say f tiles by A dilations. When $f = I_E$ a.e. is the indicator function on the set E and f tiles \mathbb{R}^n by translations (resp. dilations), we say that E tiles \mathbb{R}^n by translations (resp. dilations). Under many conditions on A , when $\mathcal{D} = \{A^j : j \in \mathbb{Z}\}$, a function ψ is a (\mathcal{D}, Γ) wavelet if and only if $|\hat{\psi}|^2$ tiles \mathbb{R}^n by Γ' translations and A^t dilations, and $\hat{\psi}$ satisfies an additional pointwise orthogonality condition. (See Theorem 4.1 for a precise statement of this condition.) We denote $\sigma_{f, \Gamma}(x) = \sum_{\gamma \in \Gamma} |f(x + \gamma)|^2$ and $\Delta_{f, \mathcal{D}}(x) = \sum_{A \in \mathcal{D}} |f(Ax)|^2$. When $\mathcal{D} = \{A^j : j \in \mathbb{Z}\}$, we may write $\Delta_{f, A}$. When $f = I_E$ and $\sigma_{f, \Gamma} \leq 1$ (resp. $\Delta_{f, A} \leq 1$), we say that E packs \mathbb{R}^n by Γ translations (resp. \mathcal{D} dilations). When any of the subscripts of σ or Δ are obvious from context, we will omit them. Given a set F that tiles \mathbb{R}^n by Γ translations, we denote the translation projection onto F by $\tau = \tau_F(E) = \cup_{\gamma \in \Gamma} ((E + \gamma) \cap F)$. Given a set G that tiles by \mathcal{D} dilations, we denote the dilation projection onto G by $d = d_G(E) = \cup_{A \in \mathcal{D}} (A(E) \cap G)$. Finally, observe that if f tiles by Γ translations and A dilations, then $\tilde{f}(x) = f(U^{-1}x)$ tiles by UAU^{-1} dilations and $U\Gamma$ translations.

2. Block matrices

In this section, we study the case when the dilation matrix can be written as a block matrix that interacts “nicely” with the lattice of translations.

We begin with a lemma that generalizes the obvious fact that the height of a rectangle which packs \mathbb{R}^n by \mathbb{Z}^n translations is bounded independent of the width.

Lemma 2.1

Let Γ be a lattice in $\mathbb{R}^{n_1} \times \mathbb{R}^{n_2}$ such that $\Gamma_0 = \Gamma \cap (0 \times \mathbb{R}^{n_2})$ is a full rank lattice in \mathbb{R}^{n_2} . Let F_0 be a fundamental region for Γ_0 , F a fundamental region for Γ , and K a set in \mathbb{R}^{n_1} . If $\sigma_{\psi, \Gamma}(\xi) \leq 1$, then $\int_K \int_{\mathbb{R}^{n_2}} |\psi(\xi)|^2 d\xi \leq (|F_0||K| \wedge |F|)$.

Proof. We have

$$\begin{aligned}
\int_K \int_{\mathbb{R}^{n_2}} |\psi(\xi)|^2 &= \int_K \int_{\cup_{\gamma \in \Gamma_0} F_0 + \gamma} |\psi(\xi)|^2 \\
&= \int_K \sum_{\gamma \in \Gamma_0} \int_{F_0 + \gamma} |\psi(\xi)|^2 \\
&= \int_K \int_{F_0} \sum_{\gamma \in \Gamma_0} |\psi(\xi + \gamma)|^2 \\
&\leq \int_K \int_{F_0} 1 = |K| |F_0|.
\end{aligned}$$

Similarly, $\int_K \int_{\mathbb{R}^{n_2}} |\psi(\xi)|^2 \leq \int_{\mathbb{R}^n} |\psi(\xi)|^2 \leq |F|$ follows from a similar periodization argument. \square

Proposition 2.2

Let $A = \begin{pmatrix} A_1 & 0 \\ T & A_2 \end{pmatrix}$ be a lower block triangular matrix with A_1 expansive, all eigenvalues of A_2 less than or equal to one in modulus, and $|A| > 1$. Let $n_i = \text{rank}(A_i)$. Let Γ be a lattice such that $\Gamma \cap (0 \times \mathbb{R}^{n_2})$ is a full rank lattice. If $|A_2| < 1$, then for every function ψ such that $\sigma_{\psi, \Gamma}(\xi) \leq 1$ and every $K \subset \mathbb{R}^{n_1}$ of positive measure, $\int_K \int_{\mathbb{R}^{n_2}} \sum_{j \in \mathbb{Z}} |\psi(A^j \xi)|^2 < \infty$. In particular, there is no $C > 0$ such that $\Delta_\psi(\xi) \geq C > 0$ a.e.

Proof. Let $K \subset \mathbb{R}^{n_1}$ be a set of positive, finite measure. Let F be a fundamental region for Γ and F_0 be a fundamental region for Γ_0 . Then, supposing $\sigma_{\psi, \Gamma}(\xi) \leq 1$

$$\begin{aligned}
&\int_K \int_{\mathbb{R}^{n_2}} \sum_{j \in \mathbb{Z}} |\psi(A^j \xi)|^2 \\
&= \sum_{j \in \mathbb{Z}} \int_K \int_{\mathbb{R}^{n_2}} |\psi(A^j \xi)|^2 \\
&= \sum_{j \in \mathbb{Z}} \int_{A_1^j(K)} \int_{\mathbb{R}^{n_2}} |\psi(\xi)|^2 |A|^{-j} \\
&\leq \sum_{j \in \mathbb{Z}} |A|^{-j} (|A_1^j(K)| |F_0| \wedge |F|) \\
&= \sum_{j \in \mathbb{Z}} |A|^{-j} (|A_1|^j |K| |F_0| \wedge |F|), \tag{2.1}
\end{aligned}$$

where the third equality follows from the change of variables $u = A^j \xi$ and the block lower triangular nature of A , and the fourth inequality is Lemma 2.1. Now, choose the smallest J such that $j \geq J$ implies that $|A_1|^j |K| |F_0| \geq |F|$. Then, equation (2.1) is equal to

$$\sum_{j \geq J} |A|^{-j} |F| + \sum_{j < J} |K| |F_0| |A_2|^{-j},$$

which is finite since $|A| > 1$ and $|A_2| < 1$. Thus, $\int_K \int_{\mathbb{R}^{n_2}} \sum_{j \in \mathbb{Z}} |\psi(A^j \xi)|^2 < \infty$, so in particular, there is no C such that $\Delta_{\psi, A} \geq C > 0$. \square

Remark. Proposition 2.2 implies that if $\psi^i \in L^2(\mathbb{R}^n)$ for $i = 1, \dots, N$, and for each i , $\sigma_{\psi^i, \Gamma}(\xi) \leq 1$, then there is no $C > 0$ such that $\sum_{i=1}^N \Delta_{\psi^i}(\xi) \geq C > 0$.

We now complete the characterization of diagonal matrices A for which there exists a function f such that $|f|^2$ tiles \mathbb{R}^n by \mathbb{Z}^n translations and A dilations. We will need the following

Lemma 2.3

There exists a partition of \mathbb{R}^n , $\{I_m : m \geq 1\}$, such that for each real diagonal matrix D with entries ± 1 , $D(I_m) = I_m$ for all m and I_m tiles \mathbb{R}^n by \mathbb{Z}^n translations for each m .

Sketch of proof. For $n = 1$, this can be done by letting $U = [0, 1/2]$ and $U_k = (U + k) \cup (-U - k)$ for $k \in \mathbb{Z}$. Then re-order the sets $\{U_k\}$ so that they are indexed by the positive integers. Assuming the lemma for dimension $1, \dots, n-1$, let $\{I_m : m \geq 1\}$ be sets satisfying the lemma for dimension 1 and $\{L_m : m \geq 1\}$ be sets satisfying the lemma for dimension $n-1$. Then $\{L_m \times I_p : m, p \geq 1\}$ satisfies the lemma for dimension n after re-ordering so that the collection is indexed by the positive integers.

Proposition 2.4

Let A be a diagonal matrix, all of whose diagonal entries are bigger than or equal to one in absolute value. If $|A| > 1$, then there exists a set that tiles \mathbb{R}^n by \mathbb{Z}^n translations and A dilations.

Proof. Write $A = \begin{pmatrix} A_1 & 0 \\ 0 & A_2 \end{pmatrix}$, where A_1 is expansive and A_2 is idempotent. (If this is impossible, then A_1 is expansive, and the result follows from [3]). Let $n_i = \text{rank}(A_i)$, and $K = [-1/2, 1/2]^{n_1}$. Let $\{I_j : j \geq 1\}$ be as in Lemma 2.3, and $D = A_1(K) \setminus K$. Note that $\{A_1^j(D) : j \in \mathbb{Z}\}$ is a partition of \mathbb{R}^{n_1} . We claim that $W = \cup_{j=1}^{\infty} (A_1^{-j}(D) \times I_j)$ tiles \mathbb{R}^n by \mathbb{Z}^n translations and A dilations.

First, we show that $\{A^j(W)\}$ is a partition of \mathbb{R}^n . Notice that

$$\begin{aligned} A^i(W) &= \bigcup_{j=1}^{\infty} (A_1^{i-j}(D) \times A_2^i(I_j)) \\ &= \bigcup_{j=1}^{\infty} A_1^{i-j}(D) \times I_j. \end{aligned} \tag{2.2}$$

(Recall that $A_2(I_j) = I_j$ from Lemma 2.3.) So, when $i \neq k$

$$\begin{aligned} A^i(W) \cap A^k(W) &= \bigcup_{j=1}^{\infty} \bigcup_{l=1}^{\infty} (A_1^{i-j}(D) \times I_j) \cap (A_1^{k-l}(D) \times I_l) \\ &\subset \bigcup_{j,l \geq 1} (A_1^{i-j}(D) \cap A_1^{k-l}(D)) \times (I_j \cap I_l) \\ &= \emptyset, \end{aligned}$$

where the first equality is from equation (2.2), and the last equality is because when $j \neq l$, $I_j \cap I_l = \emptyset$, while when $j = l$ and $i \neq k$, $A_1^{i-j}(D) \cap A_1^{k-l}(D) = \emptyset$. Thus, $A^i(W) \cap A^k(W) = \emptyset$ when $i \neq k$.

Now,

$$\begin{aligned} \bigcup_{i \in \mathbb{Z}} A^i(W) &= \bigcup_{i \in \mathbb{Z}} \bigcup_{j \geq 1} (A_1^{i-j}(D) \times I_j) \\ &= \bigcup_{j \geq 1} \bigcup_{i \in \mathbb{Z}} (A_1^{i-j}(D) \times I_j) \\ &= \bigcup_{j \geq 1} (\mathbb{R}^{n_1} \times I_j) \\ &= \mathbb{R}^n. \end{aligned}$$

Next, we show that $\{W + k\}$ is a partition of \mathbb{R}^n . First, we show that for $k \neq m \in \mathbb{Z}^n$, $|(W + k) \cap (W + m)| = 0$. Write $k = (k_1, k_2)$ and $m = (m_1, m_2)$ with $k_i, m_i \in \mathbb{Z}^{n_i}$, $i = 1, 2$. Since $A^{-j}(D) \subset [-1/2, 1/2]^{n_1}$ for $j \geq 1$, it follows that $A^{-j}(D) + k_1$ is disjoint from $A^{-l}(D) + m_1$ unless $k_1 = m_1$. Moreover, $I_j + k_2$ is disjoint from $I_j + m_2$ since $\tau|_{I_j}$ is 1-1. Therefore, reasoning as we did in the dilation case, $|(W + k) \cap (W + m)| = 0$ unless $k = m$.

Finally,

$$\begin{aligned} \bigcup_{k \in \mathbb{Z}^n} W + k &= \bigcup_{k_1 \in \mathbb{Z}^{n_1}} \bigcup_{k_2 \in \mathbb{Z}^{n_2}} \bigcup_{j \geq 1} (A_1^{-j}(D) + k_1) \times (I_j + k_2) \\ &= \bigcup_{k_1 \in \mathbb{Z}^{n_1}} \bigcup_{j \geq 1} (A_1^{-j}(D) + k_1) \times \bigcup_{k_2 \in \mathbb{Z}^{n_2}} (I_j + k_2) \\ &= \bigcup_{k_1 \in \mathbb{Z}^{n_1}} \bigcup_{j \geq 1} (A_1^{-j}(D) + k_1) \times \mathbb{R}^{n_2} \\ &= \bigcup_{k_1 \in \mathbb{Z}^{n_1}} ([-1/2, 1/2]^{n_1} + k_1) \times \mathbb{R}^{n_2} \\ &= \mathbb{R}^n, \end{aligned}$$

as desired. \square

Corollary 2.5

Let A be a diagonal matrix with $|A| > 1$. There exists a set that tiles \mathbb{R}^n by A dilations and \mathbb{Z}^n translations if and only if all the diagonal entries of A are bigger than or equal to one in absolute value.

3. Results in the plane

In this section, we restrict attention to \mathbb{R}^2 . We note here the following Lemma, whose proof is omitted.

Lemma 3.1

Let E_n be a sequence of measurable sets in $L^2(\mathbb{R}^n)$. Suppose that there is a set E such that $|E_n \triangle E| \rightarrow 0$.

(1) If E_n packs [resp. tiles] \mathbb{R}^n by translations, then E packs [resp. tiles] \mathbb{R}^n by translations.

(2) If E_n packs \mathbb{R}^n by A dilations, then E packs \mathbb{R}^n by A dilations.

Recall that the obstacle to constructing sets that tile by \mathbb{Z}^n translations and A dilations was Lemma 2.1, which stated that the height of rectangles R for which $\tau|_R$ is injective is bounded independent from the width of the rectangle. When the lattice Γ does not contain a point on the y -axis, this is not true as will be seen in Theorem 3.2. Moreover, when the height of the rectangle can be increased as the width decreases as below, we will see that sets that tile both by Γ translations and A dilations can be constructed even when A is far from expansive. Fix Γ a lattice with fundamental region F and translation projection τ_F . We begin with

Theorem 3.2

Let $A = \begin{pmatrix} a & 0 \\ 0 & b \end{pmatrix}$ with $|ab| > 1$. Let $\mathcal{D} = \{A^m : m \in \mathbb{Z}\}$. If for every rectangle $R \subset \mathbb{R}^2$ there is an M such that whenever $-\infty < m \leq M$, $A^m R$ packs \mathbb{R}^2 by Γ translations, then there is a set $U \subset [-a, a] \times \mathbb{R}$ that packs \mathbb{R}^2 by translations and tiles \mathbb{R}^2 by \mathcal{D} dilations.

Proof. Note that $D := ([-a, -1] \cup [1, a]) \times \mathbb{R}$ tiles \mathbb{R}^2 by A dilations. Let d denote the dilation projection onto D via elements of \mathcal{D} . It is clear from the hypothesis of the theorem that for any bounded set B , there exists an M such that $m \leq M$ implies $\tau|_{A^m B}$ is injective.

Define $U_n = ([-a, -1] \cup [1, a]) \times [-n, n]$ for $n \geq 1$. Let $n_1 = 1$. Choose m_1 such that $\tau|_{A^{m_1} U_1}$ is injective and $|A^{m_1} U_1| < n_1$. Now, supposing that n_1, \dots, n_{k-1} and m_1, \dots, m_{k-1} have been chosen, we choose $n_k < \frac{|A^{m_{k-1}} U_{k-1}|}{2^k}$. Then, choose m_k such that $\tau|_{A^{m_k} U_k}$ is injective and $|A^{m_k} U_k| < n_k$. Two observations about n_j that we will need are

$$n_j < |A^{m_i} U_i|/2^j, \quad \text{for } 1 \leq i < j,$$

and

$$\begin{aligned} \sum_{j=k}^{\infty} n_j &< \sum_{j=k}^{\infty} |A^{m_{j-1}} U_{j-1}|/2^j \\ &< \sum_{j=k}^{\infty} |A^{m_{k-1}} U_{k-1}|/2^j \\ &= \frac{|A^{m_{k-1}} U_{k-1}|}{2^{k-1}}. \end{aligned} \tag{3.1}$$

We proceed to define U . Let $V_1 = A^{m_1} U_1$. Let $\tilde{V}_2 = A^{m_2} U_2$, $I_2 = \tau^{-1}(\tau(V_1) \cap \tau(\tilde{V}_2)) \cap V_1$, and let $V_2 = A^{m_2}(U_2 \setminus U_1) \cup A^{m_2}(d(I_2)) \cup (V_1 \setminus I_2)$. Note that $|I_2| \leq |\tilde{V}_2| < n_2$.

In general, let

$$\begin{aligned}\tilde{V}_k &= A^{m_k}(U_k) \\ I_k &= \tau^{-1}(\tau(V_{k-1}) \cap \tau(\tilde{V}_k)) \cap V_{k-1} \\ V_k &= A^{m_k}(U_k \setminus U_{k-1}) \cup A^{m_k}(d(I_k)) \cup (V_{k-1} \setminus I_k).\end{aligned}$$

Note that $|I_k| \leq |\tilde{V}_k| < n_k$.

We proceed to prove four facts about the collection $\{V_k\}$.

Claim 1: $d(V_k) = U_k$ and $d|_{U_k}$ is injective. Indeed, note that

$$d(V_k) = (U_k \setminus U_{k-1}) \cup d(I_k) \cup (d(V_{k-1}) \setminus d(I_k)) = (U_k \setminus U_{k-1}) \cup d(V_{k-1}).$$

Since $d(V_1) = U_1$, an inductive argument shows that $d(V_k) = U_k$. Now, since $I_k \subset V_{k-1}$, it follows that $d(I_k)$, $(U_k \setminus U_{k-1})$ and $d(V_{k-1}) \setminus d(I_k)$ are pairwise disjoint. Since d is injective on each of the three pieces comprising the definition of V_k , this allows us to conclude that d is injective.

Claim 2: $\tau|_{V_k}$ is injective. Since $I_k \subset V_{k-1}$, $d(I_k) \subset U_{k-1}$. Therefore, τ restricted to the set $A^{m_k}(U_k \setminus U_{k-1}) \cup A^{m_k}(d(I_k))$ is injective. Now,

$$\tau(V_{k-1} \setminus I_k) \cap \tau(A^{m_k}(U_k \setminus U_{k-1}) \cup A^{m_k}(d(I_k))) = \emptyset$$

by the definition of I_k . So, if τ is injective when restricted to V_{k-1} , then $\tau|_{V_k}$ is also injective. Induction then proves the result.

Claim 3: $|V_k \Delta V_{k-1}| < 3n_k$. Indeed,

$$|V_k \Delta V_{k-1}| \leq |I_k| + |A^{m_k}d(I_k)| + |A^{m_k}(U_k \setminus U_{k-1})| \leq |I_k| + |\tilde{V}_k| + |\tilde{V}_k| < 3n_k.$$

Claim 4: $|\bigcap_{k=l}^{\infty} V_k| \geq |V_l| - \sum_{k=l+1}^{\infty} n_k$. Indeed, we show that $\bigcap_{k=l}^{\infty} V_k \supset V_l \setminus (\bigcup_{k=l+1}^{\infty} I_k)$ for all $l \geq 1$. If $x \in V_l \setminus (\bigcup_{k=l+1}^{\infty} I_k)$, then clearly $x \in V_l$. Since $x \notin I_{l+1}$, $x \in V_l \setminus I_{l+1} \subset V_{l+1}$. Continuing in this fashion gives $x \in \bigcap_{k=l}^{\infty} V_k$. This implies that

$$\begin{aligned}\left| \bigcap_{k=l}^{\infty} V_k \right| &\geq |V_l \setminus (\bigcup_{k=l+1}^{\infty} I_k)| \\ &\geq |V_l| - \sum_{k=l+1}^r |I_k| \\ &\geq |V_l| - \sum_{k=l+1}^r n_k.\end{aligned}$$

Continuing with the proof of the theorem, by claim 3 and the fact that $\sum n_j < \infty$, the sequence $\{V_k\}$ is Cauchy in the symmetric difference metric, so there is a set V such that $V_k \rightarrow V$. By Lemma 3.1 and claims 1 and 2, $\tau|_V$ is bijective and $d|_V$ is injective. It remains to show that $d(V) = D$. We show that each bounded set E of

positive measure contained in D has non-empty intersection with $d(V)$. Choose L such that $\frac{|U_L|}{2^L} < |E|$ and $E \subset U_L$. Then, note that $|d^{-1}(E) \cap V_L| \geq |A^{m_L}||E|$ and

$$|\cap_{j=L}^{\infty} V_j| \geq |V_L| - \sum_{j=L+1}^{\infty} n_j \geq |V_L| - |A^{m_L}||U_L|2^{-L}$$

by equation (3.1). In addition, since $V_L \supset (d^{-1}(E) \cap V_L) \cup (\cap_{j=L}^{\infty} V_j)$, it follows that

$$\begin{aligned} |V_L| &\geq \left| (d^{-1}(E) \cap V_L) \cup (\cap_{j=L}^{\infty} V_j) \right| \\ &= \left| d^{-1}(E) \cap V_L \right| + \left| \cap_{j=L}^{\infty} V_j \right| - \left| d^{-1}(E) \cap V_L \cap \cap_{j=L}^{\infty} V_j \right| \\ &\geq |A^{m_L}||E| + |V_L| - |A^{m_L}||U_L|2^{-L} - |d^{-1}(E) \cap \cap_{j=L}^{\infty} V_j|, \end{aligned}$$

so

$$\left| d^{-1}(E) \cap \cap_{j=L}^{\infty} V_j \right| \geq |A^{m_L}||E| - |A^{m_L}||U_L|2^{-L} = |A^{m_L}| \left(|E| - \frac{|U_L|}{2^L} \right) > 0$$

by the choice of L . Since $\cap_{j=L}^{\infty} V_j \subset V$, it follows that $|d^{-1}(E) \cap V| \geq |d^{-1}(E) \cap \cap_{j=L}^{\infty} V_j| > 0$, as desired. \square

We now turn to examining various cases in the plane when the hypotheses of Theorem 3.2 are satisfied.

Proposition 3.3

Let $A = \begin{pmatrix} a & 0 \\ 0 & \pm 1 \end{pmatrix}$, where $a > 1$. Let $\mathcal{D} = \{A^m : m \in \mathbb{Z}\}$. Let Γ be a lattice with fundamental region F such that $\Gamma \cap \{(0, y) : y \in \mathbb{R}\} = \{0\}$. Then, for every rectangle R of finite measure, there exists an M such that for all $m \leq M$, $A^m R$ packs \mathbb{R}^2 by Γ translations.

Proof. Without loss of generality, the rectangle $R = [-n, n]^2$. Denote $Y_n = \{(0, y) : |y| \leq n\}$. Since Γ contains only the trivial element of the y -axis, τ is injective when restricted to Y_n . Indeed, if $\tau(0, y) = \tau(0, z)$, then $(0, y) + \gamma_1 = (0, z) + \gamma_2$ and $(0, y - z) = \gamma_2 - \gamma_1 \in \Gamma$. Therefore, $y - z = 0$.

Moreover, when F is chosen to be convex, the image of Y_n under τ is a finite number of line segments in F . Thus, there is an $\epsilon > 0$ such that τ restricted to $Y_{n,\epsilon} := \{(x, y) : |x| < \epsilon \text{ and } |y| \leq n\}$ is injective. Choose any M such that $a^M n < \epsilon$. Then $A^m R \subset Y_{n,\epsilon}$ for all $m \leq M$. In particular, τ restricted to $A^m R$ is injective for each $m \leq M$. \square

A more interesting example of when the hypotheses of Theorem 3.2 are satisfied is given in the following

Proposition 3.4

Let x be an irrational number approximable to order J but to no higher order. Let $\Gamma = \text{span}_{\mathbb{Z}}\{(1, 0), (x, 1)\}$, and let F be a fundamental region for Γ . Let $A = \begin{pmatrix} a & 0 \\ 0 & b \end{pmatrix}$, where $|a| > 1 > |b|$ and $|ab^{J-1}| > 1$. Then, for every rectangle R , there exists an M such that for all $m \geq M$, $A^{-m}R$ packs \mathbb{R}^2 by Γ translations.

Proof. Without loss of generality, assume $a > 1 > b > 0$. By definition of order of approximation of an irrational number (see [6, Theorem 188], for example), for any $\delta > 0$ and any constant K , the equation $|p/q - x| < K/q^{J+\delta}$ has only finitely many solutions. Thus, after fixing $\delta > 0$ chosen so that $ab^{J-1+\delta} > 1$, one can choose K small enough so that $|p/q - x| < K/q^{J+\delta}$ has no solutions. In other words, we have that $|p - qx| \geq K/q^{J-1+\delta}$ for all $p, q \in \mathbb{Z}$, $q \geq 1$.

Now, let R be a rectangle. Without loss of generality, $R = [-n, n]^2$. Choose M such that

$$(K/2n)^{1/(J-1+\delta)}(a^{1/(J-1+\delta)}b)^m/2n > 1$$

for all $m \geq M$.

Claim. The function τ restricted to $A^{-m}R$ is injective for all $m \geq M$.

Proof of claim. Note that $A^{-m}R$ is the rectangle $[-a^{-m}n, a^{-m}n] \times [-b^{-m}n, b^{-m}n]$. So, in order for $|(A^{-m}R + \gamma) \cap A^{-m}R| > 0$, it must be that $\gamma = (\gamma_1, \gamma_2)$ satisfies $\gamma_1 < 2a^{-m}n$. (That is, the translation in the x -direction must be no more than the width of the rectangle.) This says that $\gamma = p(1, 0) - q(x, 1)$ satisfies $|p - qx| < 2a^{-m}n$. So, $2a^{-m}n \geq K/q^{J-1+\delta}$ and $q \geq a^{m/(J-1+\delta)}(K/2n)^{1/(J-1+\delta)} > b^{-m}2n$. But, $q = \gamma_2$, so translating $A^{-m}R$ by γ translates in the y -direction by an amount larger than the height of the rectangle. Therefore, $|(A^{-m}R + \gamma) \cap A^{-m}R| = 0$ and τ restricted to $A^{-m}R$ is injective. \square

Remark. If x is approximable to order 2 but to no higher order in Proposition 3.4 (for example, if $x = \sqrt{2}$ [6, Theorem 188]), then the hypotheses of the proposition reduce to $|\det(A)| > 1$.

Note that what we have proven so far is that for many cases in the plane, there exist sets that tile the plane by dilations and also pack the plane by translations. It is easier to see that whenever the determinant of the dilation matrix is not 1, it is possible to tile the plane by translations while packing the plane by dilations. What is harder to see is that using these two facts, one can often construct a set which simultaneously tiles the plane by translations and dilations in the non-expansive case.

Proposition 3.5

Let $A = \begin{pmatrix} a & 0 \\ 0 & b \end{pmatrix}$ be a diagonal matrix with $|a| > 1$. Let $\mathcal{D} = \{A^m : m \in \mathbb{Z}\}$. Let Γ be any full rank lattice. Then there exists an M such that for all $m \geq M$, there is a set $U_m \subset [a^m, a^{(m+1)}] \times \mathbb{R}$ that tiles the plane by translations. Moreover, in this case, U_m packs \mathbb{R}^2 by dilations.

Proof. Choose a bounded fundamental region F for Γ and $\gamma = (\gamma_1, \gamma_2)$ such that $\gamma_1 \neq 0$. Choose M such that $a^{(M+1)} - a^M$ is bigger than the width of F plus $2\gamma_1$. Then, for each $m \geq M$, there is a k such that $F + k\gamma \subset [a^m, a^{m+1}] \times \mathbb{R}$. Moreover, since U_m is a subset of a set that tiles \mathbb{R}^2 by \mathcal{D} dilations, U_m packs \mathbb{R}^2 by \mathcal{D} dilations. \square

Proposition 3.6

Let $A = \begin{pmatrix} a & 0 \\ 0 & b \end{pmatrix}$ be a diagonal matrix with $|a| > 1$. Let $\mathcal{D} = \{A^m : m \in \mathbb{Z}\}$. Let Γ be any full rank lattice. If there exists a set $U \subset [-a, a] \times \mathbb{R}$ that tiles by A dilations and packs by Γ translations then there exists a set W which tiles \mathbb{R}^2 by Γ translations and A dilations.

Proof. This is essentially the same proof as a result of Ionascu and Pearcy [9] in the dyadic case, but there are several modifications to be made. Choose J such that there is a set $G \subset [a^J, a^{(J+1)}] \times \mathbb{R}$ which tiles by translations and packs by dilations (as in Proposition 3.5), and such that $[a^J, a^{(J+1)}] \cap [-a, a] = \emptyset$. For this choice of J

$$V \subset G \implies |d(V)| \leq |A|^{-1}|V|. \tag{3.2}$$

For the remainder of this proof, τ will denote the translation projection onto G and d will denote the dilation projection onto U .

Define $W_1 = U$, and $W_k = (W_{k-1} \cup (G \setminus \tau(W_{k-1})) \setminus d(G \setminus \tau(W_{k-1})))$. Now, note that W_k tiles \mathbb{R}^2 by dilations for each k and that τ restricted to W_k is injective for each k .

Now, we compute

$$\begin{aligned} |W_{k-1} \Delta W_k| &= |G \setminus \tau(W_{k-1})| + |d(G \setminus \tau(W_{k-1}))| \\ &\leq 2|G \setminus \tau(W_{k-1})|. \end{aligned} \tag{3.3}$$

In addition,

$$\begin{aligned} |W_k| &\geq |W_{k-1}| + (|G| - |W_{k-1}|) - |A|^{-1}(|G| - |W_{k-1}|) \\ &= |W_{k-1}| + (1 - |A|^{-1})(|G| - |W_{k-1}|), \end{aligned} \tag{3.4}$$

where the first inequality in equation (3.4) is due to the definition of W_k and equation (3.2). Equation (3.4) implies that $|W_k| \rightarrow |G|$. Moreover, note that the recursive relation $a_k = a_{k-1} + \alpha(N - a_{k-1})$ yields $N - a_k = (1 - \alpha)^{k-1}(N - a_1)$, so if $0 < \alpha < 1$, $N - a_k$ is summable. Therefore, by equation (3.3), $|W_k \Delta W_{k-1}|$ is summable and W_k is a Cauchy sequence in the symmetric difference metric; hence, W_k converges to some W .

We claim that W tiles \mathbb{R}^2 by Γ translations and A dilations. Indeed, note that by Lemma 3.1, τ restricted to W is injective, and since $|W| = |G|$, τ restricted to W is a bijection. Also by Lemma 3.1, d restricted to W is injective, so it remains to show that $d(W) = U$, the dilation generator of \mathbb{R}^2 . To see this, let $V \subset U$ be a set of positive

measure. We show that $|d(W) \cap V| > 0$. By equation (3.2), if $K \subset W_k$ is chosen so that $d(K) = V$, then $|K| \geq |V|$. Choose k such that $|W_k \Delta W| < |V|$. Then,

$$\begin{aligned} |K| &= |W_k \cap K| = |(W \cap W_k \cap K) \cup (\tilde{W} \cap W_k \cap K)| \\ &\leq |W \cap K| + |W_k \Delta W| \\ &< |W \cap K| + |V| \leq |W \cap K| + |K|. \end{aligned}$$

So, $|W \cap K| > 0$ and $|d(W) \cap d(K)| = |d(W) \cap V| > 0$, as desired. \square

Corollary 3.7

Let $|a| > 1 > |b|$. Then, there is a matrix G with eigenvalues a and b for which there exists a set that tiles \mathbb{R}^2 by \mathbb{Z}^2 translations and G dilations and a matrix B with eigenvalues a and b for which no set tiles \mathbb{R}^2 by \mathbb{Z}^2 translations and B dilations.

Proof. Without loss of generality $|ab| > 1$. By Proposition 3.4, $A = \begin{pmatrix} a & 0 \\ 0 & b \end{pmatrix}$ satisfies the hypotheses of Theorem 3.2 with $\Gamma = \text{span}_{\mathbb{Z}}\{(1, 0), (\sqrt{2}, 1)\}$. Combining this with Propositions 3.5 and 3.6, one obtains a set that tiles both by Γ translations and A dilations. Let $U = \begin{pmatrix} 1 & 0 \\ -1 & \sqrt{2} \end{pmatrix}$. Then, $U\Gamma = \mathbb{Z}^n$ and $G = UAU^{-1}$ is the desired dilation matrix.

The matrix B can be chosen to be $\begin{pmatrix} a & 0 \\ 0 & b \end{pmatrix}$, as in Corollary 2.5. \square

Corollary 3.8

Let A be a 2×2 matrix with eigenvalues $|a| > 1$ and $|\lambda| = 1$, and Γ a full rank lattice. Then, there is a set that tiles \mathbb{R}^2 by Γ translations and A dilations.

Proof. It suffices to show that if A is diagonal and Γ is any lattice, then there exists a set that tiles \mathbb{R}^2 by Γ translations and A dilations. First, note that if $\Gamma \cap y\text{-axis} = \{0\}$, then the result follows from Proposition 3.3 and Proposition 3.6. Next, suppose that there exists a $b \neq 0$ such that $(0, b) \in \Gamma$. Choose the smallest $b > 0$ such that $(0, b) \in \Gamma$, the smallest d such that there exists a y with $(d, y) \in \Gamma$, and the smallest c such that $(d, c) \in \Gamma$. Then, $\text{span}_{\mathbb{Z}}\{(0, b), (d, c)\} = \Gamma$, so the rectangle $[-d/2, d/2] \times [-b/2, b/2]$ is a fundamental region for Γ .

Now, if $a > 1$ and $\lambda = 1$, then let

$$\begin{aligned} I_k &= [da^{-(k+1)}/2, da^{-k}/2] \times [-b/2, 0], \\ J_k &= [da^{-(k+1)}/2, da^{-k}/2] \times [0, b/2], \\ L_k &= [-da^{-(k+1)}/2, -da^{-k}/2] \times [-b/2, 0], \text{ and} \\ M_k &= [-da^{-(k+1)}/2, -da^{-k}/2] \times [0, b/2]. \end{aligned}$$

Let

$$\begin{aligned} W &= \bigcup_{k \geq 0} (I_k + kb) \cup \bigcup_{k \geq 0} (J_k - kb) \cup \bigcup_{k \geq 0} (L_k - kb) \cup \bigcup_{k \geq 0} (M_k + kb) \\ &\cup \bigcup_{k > 0} (I_k - kb) \cup \bigcup_{k > 0} (J_k + kb) \cup \bigcup_{k > 0} (L_k + kb) \cup \bigcup_{k > 0} (M_k - kb). \end{aligned}$$

It follows from inspection that W tiles \mathbb{R}^2 by Γ translations and A dilations. The set W is also symmetric in x and y , so we can see that the same set will work for $a < -1$ and/or $\lambda = -1$. \square

Finally, we turn to trying to understand exactly what the prototiles that we have constructed look like. It follows from [13] that whenever the dilation matrix is not expansive, the sets must be unbounded. If one reads carefully the proofs of the theorems above, one can see that the prototiles constructed in the fashion of the proofs when Γ does not intersect the y -axis may also have *empty interior*. This is not solely an artifact of the construction, as the next proposition shows.

Proposition 3.9

Let $A = \begin{pmatrix} a & 0 \\ 0 & 1 \end{pmatrix}$, and suppose that Γ does not intersect the y -axis. Then, every set that tiles \mathbb{R}^2 by A dilations and Γ translations is unbounded with empty interior.

Proof. Let W be a set with non-empty interior that tiles \mathbb{R}^2 by A dilations and Γ translations. We derive a contradiction. Let R be a square of length 4ϵ such that $R \subset W$. Then R packs \mathbb{R}^2 . Let Y denote the y -axis. Since $\tau(Y)$ is dense in the fundamental region F , $\tau(Y)$ intersects $\tau(R)$ within ϵ of the center of R infinitely often. That is, there exist $\{\gamma_i\}_{i=1}^\infty \subset \Gamma$, no two of which are equal, such that $(R + \gamma_i)$ intersects Y within ϵ of the center of R . Now, assuming none of the γ_i are 0, $|(R + \gamma_i) \cap W| = 0$ for all i . So, since τ restricted to W is injective, it follows that on each horizontal strip S_i of height 4ϵ centered at the center of $R + \gamma_i$, the projection of $W \cap S_i$ onto the x -axis is contained in $(-\infty, -\epsilon] \cup [\epsilon, \infty)$. Now, since $\cup_{j \in \mathbb{Z}} A^j W \supset S$, we obtain that $|W \cap S_i| \geq a\epsilon$ (equality is obtained when $W \cap S_i = ([-a\epsilon, -\epsilon] \cup [\epsilon, a\epsilon]) \times P_Y(R + \gamma_i)$, where P_Y is the projection onto the y -axis). Since there are infinitely many γ_i and the S_i are disjoint, it follows that $|W| = \infty$. This is a contradiction. \square

Remark. It was noted in [15] that it is not known whether there are dilation sets \mathcal{D} such that the only sets that tile by \mathcal{D} dilations have empty interior. Proposition 3.9 provides another example that in the non-expansive case, the interplay between the dilations and the translations is crucial.

On the other hand, when $A = \begin{pmatrix} a & 0 \\ 0 & \pm 1 \end{pmatrix}$, one can find a nice picture of sets that tile by A dilations and \mathbb{Z}^2 translations. Following the proofs in Proposition 2.4 in this special case yields the following picture (see Figure 1). A similar picture has appeared in [2] and [8].

4. Applications to wavelets

In this section, we apply the theorems above to the existence of wavelets. Recall the definitions of wavelets and MSF wavelets given in Section 1. It is also known [7] that if $\{\psi(x+k) : k \in \Gamma\}$ is a (not necessarily complete) orthonormal system (in particular, if ψ is a wavelet), then $\sigma_{\hat{\psi}, \Gamma'}(\xi) = 1$ a.e.

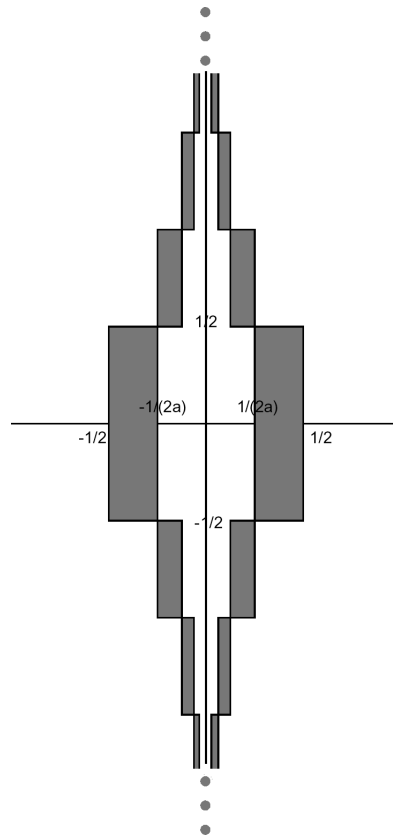

Figure 1: Set that tiles via powers of $A = \begin{pmatrix} a & 0 \\ 0 & \pm 1 \end{pmatrix}$ and integer translations.

The most general characterization of wavelets via the Fourier transform to date was given in [8]. Given $M \in GL_n(\mathbb{R})$ and a non-zero linear subspace F of \mathbb{R}^n , we say that M is expanding on F if there exists a complementary (not necessarily orthogonal) linear subspace E of \mathbb{R}^n with the following properties:

- (1) $\mathbb{R}^n = F + E$ and $F \cap E = \{0\}$;
- (2) $M(F) = F$ and $M(E) = E$, that is, E and F are invariant under M ;
- (3) there exists $0 < k \leq 1 < \gamma < \infty$ such that $|M^j x| \geq k\gamma^j |x|$ when $x \in F$, $j \geq 0$;
- (4) given $r \in \mathbb{N}$, there exists $C = C(M, r)$ such that for all $j \in \mathbb{Z}$, the set

$$Z_r^j(E) = \{m \in E \cap \mathbb{Z}^n : |M^j m| < r\}$$

has less than C elements. Note that if all eigenvalues of a matrix are bigger than one in modulus, then the matrix is expanding on \mathbb{R}^n .

Theorem 4.1

[8, Theorem 5.3] Let $\psi \in L^2(\mathbb{R}^n)$ and A such that $B = A^t$ is expanding on a subspace F of \mathbb{R}^n . Then, ψ is an (A, \mathbb{Z}^n) wavelet if and only if

$$\sigma_{\hat{\psi}, \mathbb{Z}^n}(\xi) = 1 \text{ a.e., and}$$

$$\sum_{j \in P_\alpha} \hat{\psi}(B^{-j}\xi) \overline{\hat{\psi}(B^{-j}(\xi + \alpha))} = \delta_{\alpha,0}$$

for all $\alpha \in \Lambda = \cup_{j \in \mathbb{Z}} B^j(\mathbb{Z}^n)$ and $P_\alpha = \{j \in \mathbb{Z} : B^{-j}\alpha \in \mathbb{Z}^n\}$.

Note that when $\alpha = 0$, the second condition of Theorem 4.1 becomes $\Delta_{\hat{\psi},B}(\xi) = 1$ a.e. This is also called the discrete Calderón condition. It is not known in general whether the discrete Calderón condition is necessary for a function to be a wavelet, though it seems very likely.

We are now ready to interpret the results of the previous sections for wavelets.

Theorem 4.2

Let A be a diagonal matrix with determinant bigger than 1. There exists an (A, \mathbb{Z}^n) wavelet that satisfies the discrete Calderón condition if and only if all diagonal entries of A are bigger than or equal to 1.

Proof. Apply Proposition 2.2 and Proposition 2.4. \square

Remark. Proposition 2.2 can be applied to prove that the upper block triangular matrices described in Proposition 2.2 do not admit wavelets which satisfy the discrete Calderón condition. By the remark following Proposition 2.2, these dilations do not even admit multiwavelets which satisfy the discrete Calderón condition.

Theorem 4.3

Let $|a| > 1 > |b|$. There is a matrix A with eigenvalues a and b such that there exists an (A, \mathbb{Z}^2) wavelet and a matrix M with eigenvalues a and b for which there does not exist an (M, \mathbb{Z}^2) wavelet.

Proof. The matrix for which there exists a wavelet is given by Corollary 3.7. For the other half, we showed in Proposition 2.2 that no wavelet satisfying the Calderón condition can exist for $M^t = \begin{pmatrix} a & 0 \\ c & b \end{pmatrix}$ for any c . Choose c such that $(a - b)/c$ is irrational. Then, while M^t is not expanding on a subspace, $M^{t-1} = \begin{pmatrix} 1/a & 0 \\ -c/(ab) & 1/b \end{pmatrix}$ is expanding on the subspace $F = \{(0, y) : y \in \mathbb{R}\}$ with complementary subspace $E = \{(x(a - b)/c, x) : x \in \mathbb{R}\}$. (This follows since $E \cap \mathbb{Z} = \{0\}$.) Therefore, every M^{-1} wavelet satisfies the discrete Calderón condition, and by symmetry every M wavelet must satisfy the discrete Calderón condition. Therefore, no M wavelets can exist. \square

We present now several two dimensional examples that illustrate the progress made in this paper and open questions that still remain. These examples also illustrate the delicate nature of the arguments presented in this paper, as the existence of wavelets for non-expansive dilations is related to the interplay between the eigenvectors of A and the integer lattice, not merely the eigenvalues. (Here, we have translated all of the previous results back to the standard lattice \mathbb{Z}^2 .)

EXAMPLES:

- (i) $A = \begin{pmatrix} 2 & 0 \\ 0 & 2/3 \end{pmatrix}$, $\Gamma = \mathbb{Z}^2$. No MSF (multi)-wavelets can exist, and no (multi)-wavelet can exist that also satisfies the discrete Calderón condition. It is not known whether all wavelets must satisfy the discrete Calderón condition for this dilation.
- (ii) $A = \begin{pmatrix} 2 & \sqrt{2} \\ 0 & 2/3 \end{pmatrix}$, $\Gamma = \mathbb{Z}^2$. No (multi)-wavelets can exist for this dilation.
- (iii) $A = \begin{pmatrix} 2 & 0 \\ \sqrt{2} & 2/3 \end{pmatrix}$, $\Gamma = \mathbb{Z}^2$. MSF wavelets exist for this dilation.
- (iv) $A = \begin{pmatrix} 2 & 0 \\ \sqrt[3]{2} & 2/3 \end{pmatrix}$, $\Gamma = \mathbb{Z}^2$. It is not known whether MSF wavelets exist for this dilation, since $\sqrt[3]{2}$ is approximable to order 3 and no higher order, but $2(2/3)^2 < 1$.
- (v) $A = \begin{pmatrix} 2 & 0 \\ \sqrt[3]{2} & 3/4 \end{pmatrix}$, $\Gamma = \mathbb{Z}^2$. MSF wavelets exist for this dilation since $2(3/4)^2 > 1$.

Acknowledgments. Eugenio Hernández noticed that the author's original proof of Proposition 2.2 for diagonal matrices generalizes to lower diagonal matrices, as presented in Proposition 2.2. Guido Weiss showed the author an example of a matrix with eigenvalues on both sides of 1 in modulus which is expanding on a subspace. The author also wishes to thank Marcin Bownik for showing him the reference [13] and Richard Laugesen for sharing a preprint. Qing Gu shared his thoughts with the author on whether wavelets can exist for non-expansive dilations while we were both graduate students at Texas A&M. In particular, something like Proposition 3.9 was known to him. Demetrio Labate found several errors in preliminary versions of this paper.

References

1. M. Bownik, Combined MSF multiwavelets, *J. Fourier Anal. Appl.* **8** (2002), 201–210.
2. M. Bownik and D.M. Speegle, The wavelet dimension function for real dilations and dilations admitting non-MSF wavelets, *Approximation theory, X (St. Louis, MO, 2001)*, 63–85, Innov. Appl. Math., Vanderbilt Univ. Press, Nashville, TN, 2002.
3. X. Dai, D.R. Larson, and D.M. Speegle, Wavelet sets in \mathbb{R}^n , *J. Fourier Anal. Appl.* **3** (1997), 451–456.
4. X. Fang and X. Wang, Construction of minimally supported frequency wavelets, *J. Fourier Anal. Appl.* **2** (1996), 315–327.
5. D. Han and Y. Wang, Lattice tiling and the Weyl-Heisenberg frames, *Geom. Funct. Anal.* **11** (2001), 742–758.
6. G.H. Hardy and E.M. Wright, *Introduction to the Theory of Numbers*, Oxford at the Clarendon Press, 1938.
7. E. Hernández and G. Weiss, *A First Course on Wavelets*, Studies in Advanced Mathematics, CRC Press, Boca Raton, FL, 1996.

8. E. Hernández, D. Labate, and G. Weiss, A unified characterization of reproducing systems generated by a finite family. II, *J. Geom. Anal.* **12** (2002), 615–662.
9. E.J. Ionascu and C.M. Percy, On subwavelet sets, *Proc. Amer. Math. Soc.* **126** (1998), 3549–3552.
10. M. Kolountzakis, Multi-lattice tiles, *Internat. Math. Res. Notices* **19** (1997), 937–952.
11. R. Laugesen, Completeness of orthonormal wavelet systems for arbitrary real dilations, *Appl. Comput. Harmon. Anal.* **11** (2001), 455–473.
12. R.S. Laugesen, N. Weaver, G.L. Weiss, and E.N. Wilson, A characterization of the higher dimensional groups associated with continuous wavelets, *J. Geom. Anal.* **12** (2002), 89–102.
13. E. Schulz and K. Taylor, Continuous and semi-discrete tight frames on \mathbb{R}^n , (preprint).
14. P.M. Soardi and D. Weiland, Single wavelets in n -dimensions, *J. Fourier Anal. Appl.* **4** (1998), 299–315.
15. Y. Wang, Wavelets, tilings and spectral sets, *Duke Math. J.* **114** (2002), 43–57.